



**BEAM**

## User and Installation Guide

v.22.08

# Welcome to using Thingsee

Congratulations on choosing Haltian Thingsee as your IoT solution. We at Haltian want to make IoT easy and accessible for everyone, so we have created a solution platform that is easy to use, scalable and secure. I hope our solution will help you achieve your business goals!

Pasi Leipälä  
CEO, Haltian Oy

## Thingsee BEAM



Thingsee BEAM is a wireless IoT sensor for short distance measurement. This is an excellent tool for measuring e.g. container or dispenser fill levels. Thingsee BEAM can be used for various facility management applications in smart cleaning, asset tracking and more.

Thingsee BEAM is a part of Haltian Thingsee IoT solution and product family.

## Sales package content

- Thingsee BEAM sensor
- 1 x Opening Key

## Using Thingsee BEAM sensor

Thingsee BEAM measures the distance between the sensor and any solid surface. The sensor sends a laser beam and calculates the distance from the time it takes for the beam to return back to the sensor.

Thingsee BEAM can be used to measure the fill levels of, for example, paper and towel dispensers, trash bins, shelves and even liquid dispensers with an accessory.

Thingsee BEAM gives extremely accurate distance measurement and it has an adjustable sensor beam, making the installation flexible and easy.

Please note that the measured surface needs to be solid, and that some materials, like glossy surfaces, may interfere with the beam.

## General installation instructions

Install the sensor above or below the surface you want to measure. Make sure that the sensor is at least 2 cm from the surface.

The angle between the sensor and the measured surface is recommended to be  $90^\circ$ , but it can be adjusted if needed by  $6^\circ$  to either side, making the installation flexible.

To see how to adjust the angle of the BEAM sensor, please check more info at [support.haltian.com](http://support.haltian.com)

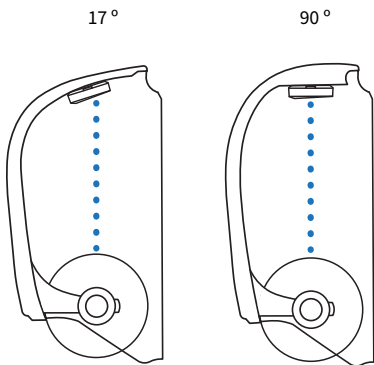

The adjustable sensor beam can be used in, for example, curved installation surfaces.

# Things to avoid in installation

Avoid installing Thingsee products near the following:

Thick concrete structures or thick fire doors

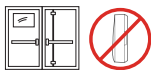

Electrical transformers or thick electrical wires

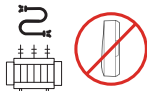

Escalators



Nearby halogen lamps, fluorescent lamps or similar lamps with hot surface

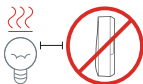

Nearby radio equipment like WiFi routers or any other similar high power RF transmitters

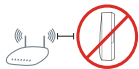

Inside metal box or covered with a metal plate.

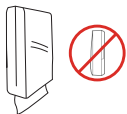

Direct sun light or bright spotlight hitting the sensor as it may interfere with the laser beam and give inaccurate results.

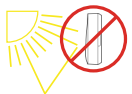

Near elevator motors or similar targets causing a strong magnet field.



# Installation

Please make sure the Thingsee gateway device is installed before you install the sensors.

To identify the sensor, read the QR code on the front of the device with a QR code reader or Thingsee installation application on your mobile device.

Identifying the device is not necessary, but it will help you keep track of your IoT installation and help Haltian support to solve possible issues.

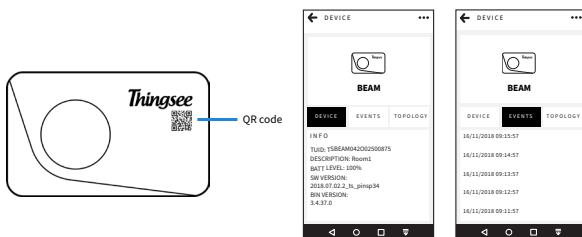

**Note:** Make sure the sensor is installed max. 20 meters from the next sensor or gateway. This is to ensure full coverage mesh network between the sensors and the gateway.

Carefully pull out the battery security tab.

Clean the surface you will attach the sensor to with IPA -solvent (isopropyl alcohol).

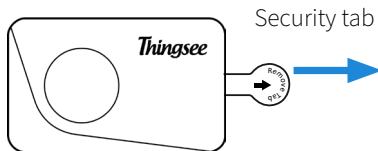

Remove the tape's paper cover from the backside of the sensor.  
Attach the sensor to its place by pushing it firmly against the surface for minimum of 5 seconds. Wipe the sensor with a clean cloth.

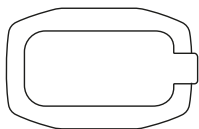

— Tape with paper cover

## Changing the batteries

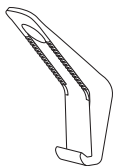

— Opening Key

When holding the sensor in hand: Place the opening key in the hole on the side of the sensor and twist to open.

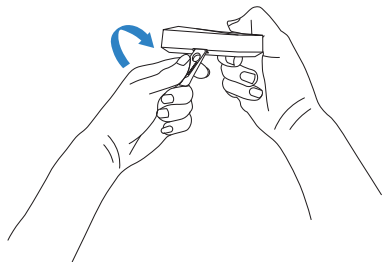

When the sensor is on the installed surface:

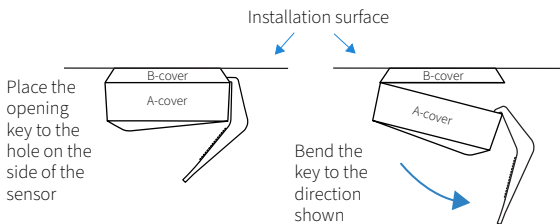

Place the batteries inside the A-cover.

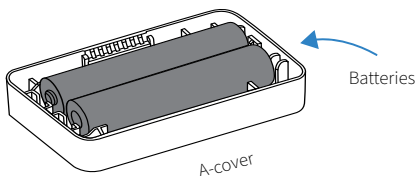

Attach the A-cover to the B-cover attached to the installed surface.

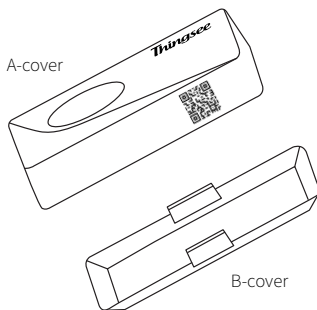



## Using Thingsee BEAM for dispenser fill level monitoring

Install the sensor on the decided location above or below the measured surface.

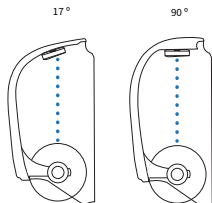

## Using Thingsee BEAM for trash bin fill level monitoring

When using a plastic bag inside the trash bin please make sure the plastic bag is not in the sensor beam area. Notice that the sensor must be facing the trashes without any disturbances between the beam and the trashes. If the trash can has only a partial lid, the sensor can be installed on the side, as long as the beam reaches the trash inside. Install the sensor on the decided location above the measured surface.

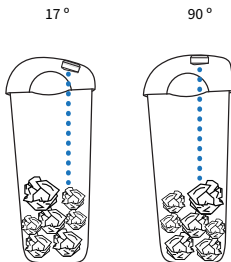

## Using Thingsee BEAM for shelf fill level monitoring

Place the sensor above and next to the monitored objects so that the sensor beam is pointing at the monitored objects.

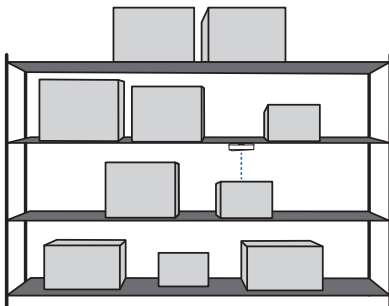

# Detection Capability

- Measurement range: 40 mm - 4000 mm.
- Ranging accuracy:  $\pm 25$  mm max, depending ambient light conditions and target reflectance.
- Test materials used: solid, matte, white, 140 mm reference distance.
- Distance sensing area is a cone shape, adjustable between 15 - 27 degrees, region of interest (ROI).

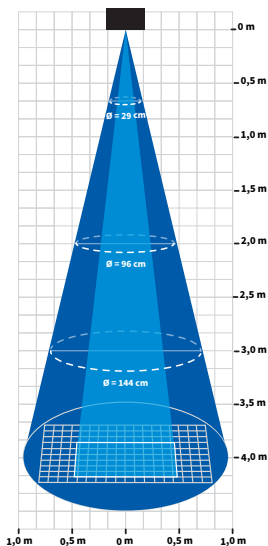

# Default measurement and reporting

Default settings:

- Measure distance every 5 minutes
- Report a distance measurement value every time when the distance has changed and every 1 hour
- Report battery-level every 6 hours
- Distance sensor measurement mode is short-range
- The sensor is in routing-mode

The following parameters are configurable remotely over Thingsee Operations Cloud:

- Measurement interval
- Reporting interval
- Reporting event threshold
- Region of Interest (ROI) from 16x16 matrix, min 4x4 enabling
- Angle of measurement
- Direction of interest
- Mesh network node role; Routing / Non-routing
- Timing budget to balance between power consumption and measurement noise

Change of distance measurement modes:

- 1: Short range mode 40 mm - 1300 mm
- 2: Long range mode up to 4000 mm

## Settings' impact on battery-life

- 1 min measurement interval up to 3 years
- 5 min measurement interval up to 4 years (default setting)
- 15 min measurement interval up to 5 years

## Device info

Operating temperature -20 °C ... +50 °C

Operating humidity 0 % ... 100 % RH non-condensing

Storage temperature +5 °C ... +25 °C

Storage humidity 45 % ... 85 % RH non-condensing

IP rating grade: IP40

Certifications: CE, FCC, ISED and RoHS compliant

Class 1 laser (safe under all conditions of normal use)

Battery type: 2 x AAA, replaceable

Radio sensitivity: -95 dBm (BTLE)

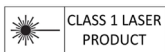

More device info can be found at [support.haltian.com](http://support.haltian.com)

## Device measurements

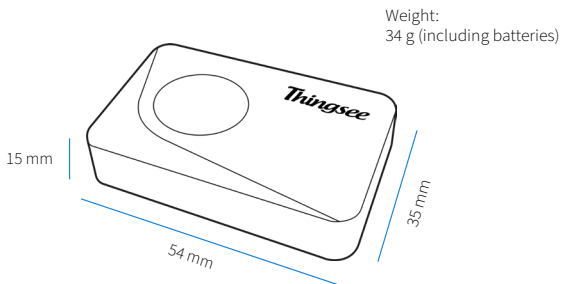

CERTIFICATION IN CERTIFICATION INFORMATION  
EU DECLARATION OF CONFORMITY

Hereby, Haltian Oy declares that the radio equipment Thingsee BEAM is in compliance with Directive 2014/53/EU. The full text of the EU Declaration of conformity is available at the following internet address: thingsee.com

Haltian Oy vakuuttaa, että radiolaitetyyppi Thingsee BEAM on direktiivin 2014/53/EU mukainen. EU-vaatimustenmukaisuusvakuutuksen täysimittainen teksti on saatavilla seuraavassa internetosoitteessa: thingsee.com

Thingsee BEAM operates at Bluetooth® 2.4 GHz frequency band. Maximum radio-frequency power transmitted is +4.0 dBm.

Manufacturer name and address:

Haltian Oy  
Yrttipellontie 1 D  
90230 Oulu  
Finland

FCC REQUIREMENTS FOR OPERATION IN THE UNITED STATES

FCC Information for the User

This product does not contain any user serviceable components and is to be used with approved, internal antennas only. Any product changes of modifications will invalidate all applicable regulatory certifications and approvals.

FCC Guidelines for human Exposure

This equipment complies with FCC radiation exposure limits set forth for an uncontrolled environment. This equipment should be installed and operated with minimum distance of 20 cm between the radiator and your body. This transmitter must not be co-located or operating in conjunction with any other antenna or transmitter.

FCC Radio Frequency Interference Warnings & Instructions

This equipment has been tested and found to comply with the limits for a Class B digital device, pursuant to Part 15 of the FCC Rules. These limits are designed to provide reasonable protection against harmful interference in a residential installation. This equipment uses and can radiate radio frequency energy and, if not installed and used in accordance with the instructions, may cause harmful interference to radio communications. However, there is no guarantee that interference will not occur in a particular installation. If this equipment does cause harmful interference to radio or television reception, which can be determined by turning the equipment off and on, the user is encouraged to try to correct the interference by one or more of the following methods:

Increase the separation between the equipment and the receiver.

Connect the equipment into an electrical outlet on a circuit different from that which the radio receiver is connected

Consult the dealer or an experienced radio/TV technician for help

Any changes or modifications not expressly approved by the party responsible for compliance could void the user's authority to operate this equipment.

FCC compliance statement:

This device complies with Part 15 of the FCC Rules. Operation is subject to the following two conditions: (1) this device may not cause harmful interference, and (2) this device must accept any interference received, including interference that may cause undesired operation.

Innovation, Science and Economic Development Canada (ISED) regulatory information

This device complies with RSS-247 of the Innovation, Science and Economic Development Canada (ISED) Rules. Operation is subject to the following two conditions: (1) This device may not cause harmful interference, and (2) this device must accept any interference received, including interference that may cause undesired operation.

Ce dispositif est conforme à la norme CNR-247 d'Innovation, Sciences et Développement économique Canada applicable aux appareils radio exempts de licence. Son fonctionnement est sujet aux deux conditions suivantes: (1) le dispositif ne doit pas produire de brouillage préjudiciable, et (2) ce dispositif doit accepter tout brouillage reçu, y compris un brouillage susceptible de provoquer un fonctionnement indésirable

Radiation Exposure Statement :

This device complies with ISED radiation exposure limits set forth for an uncontrolled environment. This equipment must be installed and used with a minimum distance of 20 cm between the radiator and your body.

**NOTE IMPORTANTE: Déclaration d'exposition aux radiations:**

Cet équipement est conforme aux limites d'exposition aux rayonnements ISED établies pour un environnement non contrôlé. Cet équipement doit être installé et utilisé avec une distance minimale de 20 cm entre le radiateur et votre corps.

FCC ID: 20236-TSBEAM

IC ID: 2AEU3TSBEAM

**SAFETY GUIDE**

Read these simple guidelines. Not following them may be dangerous or against local laws and regulations. For further information, read the user guide and visit [www.haltian.com](http://www.haltian.com)

**Usage**

Do not cover the device as it prevents the device from operating properly.

- This product is intended for indoor use only and shall not be exposed to rain.
- Do not modify the device. Unauthorized modifications may damage the device and violate regulations governing radio devices.
- Do not store the device in wet or humid conditions.
- Remove the batteries from the device if you are taking it inside an aeroplane (unless you have the pre-installed pull-out tape still in place). The device has a Bluetooth LE receiver/transmitter which must not be operational during a flight.
- Please take care that the used batteries are recycled by taking them to appropriate collection point.
- When changing batteries, replace both of them at the same time using identical brand and type.
- Do not swallow batteries.
- Do not throw batteries into water or fire.
- Do not short-circuit batteries.
- Do not try to charge primary batteries.
- Do not open or disassemble batteries.
- Batteries should be stored in a dry place and at room temperature. Avoid large temperature changes and direct sunlight. At higher temperature the electrical performance of the batteries may be reduced.
- Keep batteries away from children.

**Care and maintenance**

Handle your device with care. The following suggestions help you keep your device operational.

- Do not open the device other than as instructed in the user guide.
- Unauthorized modifications may damage the device and violate regulations governing radio devices.
- Do not drop, knock, or shake the device. Rough handling can break it.
- Only use a soft, clean, dry cloth to clean the surface of the device. Do not clean the device with solvents, toxic chemicals or strong detergents as they may damage your device and void the warranty.
- Do not paint the device. Paint can prevent proper operation.

**Damage**

If the device is damaged contact [support@haltian.com](mailto:support@haltian.com). Only qualified personnel may repair this device.

**Small children**

Your device is not a toy. It may contain small parts. Keep them out of the reach of small children.

**RECYCLING**

Check the local regulations for proper disposal of electronic products. The Directive on Waste Electrical and Electronic Equipment (WEEE), which entered into force as European law on 13th February 2003, resulted in a major change in the treatment of electrical equipment at end-of-life. The purpose of this Directive is, as a first priority, the prevention of WEEE, and in addition, to promote the reuse, recycling and other forms of recovery of such wastes so as to reduce disposal.

The crossed-out wheelee-bin symbol on your product, battery, literature, or packaging reminds you that all electrical and electronic products and batteries must be taken to separate collection at the end of their working life. Do not dispose of these products as unsorted municipal waste: take them for recycling. For info on your nearest recycling point, check with your local waste authority.



Innovation, Science and  
Economic Development Canada

Innovation, Sciences et  
Développement économique Canada



## Get to know other Thingsee devices



Thingsee PRESENCE



Thingsee ENVIRONMENT

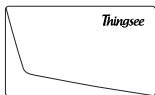

Thingsee AIR



Thingsee BEAM



Thingsee ENVIRONMENT  
RUGGED



Thingsee LEAKAGE  
RUGGED



Thingsee ANGLE  
RUGGED



Thingsee  
COUNT

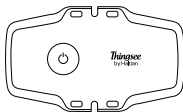

Thingsee GATEWAY  
GLOBAL

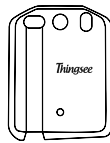

Thingsee GATEWAY  
LAN

For all devices and more information, visit our website  
[www.haltian.com](http://www.haltian.com) or contact [sales@haltian.com](mailto:sales@haltian.com)